

# Easyroll 150mm Grey Rubber Swivel Brake G6 Series Castor 130kg

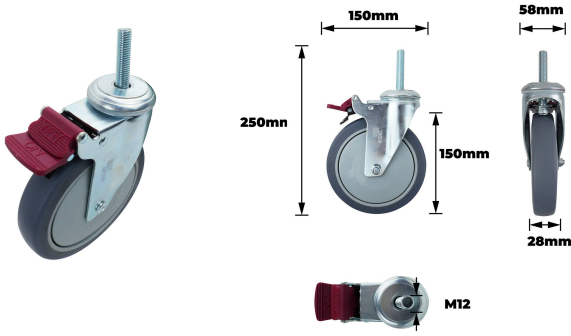

## Description

Easyroll 150mm Grey Rubber Swivel Brake G6 Series Castor 130kg is engineered to facilitate movement and secure positioning in high-demand commercial applications. Manufactured with a steel housing and robust ball bearings, its thermoplastic rubber wheel and polypropylene core contribute to controlled manoeuvrability and effective total braking. A bolt-fitted design with a single raceway supports precision and consistent performance valued by industrial and trade professionals.

## Features

- Steel housing constructed for long-lasting structural integrity
- Thermoplastic rubber wheel provides reliable traction and durability
- Polypropylene wheel core maximises performance with low weight
- Precision ball bearing ensures smooth swivel motion
- Total brake system provides full rotational lock on demand
- Bolt mounting enables secure standardised installation
- Single raceway design facilitates precise directional tracking
- Available in grey with silver and red accents

**Product Code: G64TZ44K150**

## Specifications

Outdoor Use	Yes
Indoor Use	No
Bearing Type	Ball Bearing
Raceway Type	Single
Brake Type	Total
Fitting Type	Bolt Hole

## Appearance

Product Colour	Grey/Silver/Red
----------------	-----------------

## Construction

Wheel Core Material	Polypropylene
Wheel Material	Thermoplastic Rubber
Housing Material	Steel
Bearing Material	Bearing Steel

## Dimensions

Product Length mm	150
Product Width mm	58
Product Height mm	250
Wheel Diameter	150
Tread Width mm	28
Finish Height mm	185
Bolt Thread Length (mm)	75
Bolt Thread Width (mm)	12
Mounting Size (G) mm	M12

NSW/ACT Chris Caruana 0431 151 883 chris.c@ehi.com VIC/TAS/SA Trent Rapp 0412 444 133 trent.r@ehi.com.au  
 QLD Stephen Duncan 0458 203 917 stephen.d@ehi.com.au WA Greg Martin 0417 959 925 greg.m@ehi.com.au

[www.ehi.com.au](http://www.ehi.com.au)

For all enquiries please contact our customer service team on 1300 727 535 or at [cs@ehi.com.au](mailto:cs@ehi.com.au)

